

波纹吸盘

TGBS (2.5折)

适用于搬运易损型工件



应用：2.5折通用型吸盘多种材质可选，满足广泛应用需求，包括电子行业、玻璃行业、包装行业和注塑成型行业。



波纹吸盘TGB

亮点

- 多种尺寸和材质可选
- 2.5折波纹结构
- 波纹柔韧灵活
- 密封唇柔软且有锥度

优势

- > 适合不同尺寸和形状的工件
- > 吸盘的压缩行程长
- > 接触工件时有良好的缓冲性能，吸力柔和
- > 极易贴合曲面和表面不平整工件



波纹吸盘TGBS (2.5折) 订购指南

TGBS		18		SI-55		G1/8-IG			
吸盘接头 代码	描述	吸盘直径 ⁽¹⁾ 代码	直径	代码	直径	橡胶件 代码	材质/颜色	连接头螺纹 ⁽²⁾ 代码	螺纹
TGB	不带吸盘接头	3	Ø 3.0 mm	20	Ø 20 mm	NBR-55	丁腈橡胶	无	不带吸盘接头
TGBS	带吸盘接头	4	Ø 3.8 mm	25	Ø 23 mm	NBR-AS-55	丁腈橡胶 (防静电)	M3-AG	M3外螺纹
		5	Ø 5.0 mm	32	Ø 32 mm	SI-55	硅橡胶	M5-AG	M5外螺纹
		7	Ø 5.9 mm	42	Ø 42.6 mm	SI-AS-55	硅橡胶 (防静电)	M5-IG	M5内螺纹
		9	Ø 9.0 mm	52	Ø 52.5 mm	HT1-60	无痕橡胶	G1/8-AG	G1/8外直螺纹
		12	Ø 12.0 mm	62	Ø 62.2 mm	NK-45	天然橡胶	G1/8-IG	G1/8内直螺纹
		14	Ø 14.5 mm	88	Ø 89 mm			R1/8-AG	R1/8外锥螺纹
		18	Ø 17.2 mm					G1/4-AG	G1/4外直螺纹
								G1/4-IG	G1/4内直螺纹
								R1/4-AG	R1/4外锥螺纹

⁽¹⁾吸盘直径和螺纹型号的可用组合请参见“订购参数”。

⁽²⁾由于外锥螺纹R可装配在内直螺纹G上，因此未列出内锥螺纹Rc。



波纹吸盘 TGBS (2.5折) 技术参数

型号	吸力 [N]*	拉脱力 [N]**	内部体积 [cm³]	工件最小曲率半径 [mm] (凸形)	推荐软管直径 d [mm]***	接头系列
TGB5	0.1	0.8	0.033	8	2	N 017
TGB7	0.1	0.9	0.043	8	4	N 016
TGB9	0.7	2.3	0.150	10	4	N 016
TGB12	0.9	3.5	0.600	13	4	N 016
TGB14	1.2	5.7	0.975	15	4	N 016
TGB18	2.3	8.5	1.350	20	4	N 016
TGB20	3.8	12.1	2.000	30	4	N 016
TGB25	4.5	19.0	5.400	30	4	N 016
TGB32	12.0	36.9	10.000	35	6	N 018
TGB42	13.6	44.0	19.500	75	6	N 018
TGB52	27.0	96.0	62.000	75	6	N 018
TGB62	39.6	137.0	72.500	75	6	N 018
TGB88	45.2	286.0	165.000	100	9	N 019

*指定的吸力为理论值，真空度为 -0.6 bar，光滑、干燥表面的工件，不包括安全系数

**天然橡胶材质的吸盘，其拉脱力约降低 40%

***推荐软管使用长度约为 2 m



波纹吸盘TGBS (2.5折)

型号	吸盘材质 * / 肖氏硬度 A			
	高温材料 HT1 60±5ShA	天然橡胶 NK 45±5ShA	丁腈橡胶 NBR 55±5ShA	硅橡胶 SI 55±5ShA
TGBS 5-M5-AG	100661	-	100662	100663
TGBS 5-M5-IG	100664	-	100665	100666
TGBS 7-G1/8-AG	100667	-	100668	100669
TGBS 7-G1/8-IG	100670	-	100671	100672
TGBS 7-M5-AG	100673	-	100674	100675
TGBS 9-G1/8-AG	100676	100677	100678	100679
TGBS 9-G1/8-IG	100680	100681	100682	100683
TGBS 9-M5-AG	100684	100685	100686	100687
TGBS 12-G1/8-AG	100688	100689	100690	100691
TGBS 12-G1/8-IG	100692	100693	100694	100695
TGBS 12-M5-AG	100696	100697	100698	100699
TGBS 14-G1/8-AG	100700	100701	100702	100703
TGBS 14-G1/8-IG	100704	100705	100706	100707
TGBS 14-M5-AG	100708	100709	100710	100711
TGBS 18-G1/8-AG	100712	100713	100714	100715
TGBS 18-G1/8-IG	100716	100717	100718	100719
TGBS 18-M5-AG	100720	100721	100722	100723
TGBS 20-G1/8-AG	100724	100725	100726	100727
TGBS 20-G1/8-IG	100728	100729	100730	100731
TGBS 20-M5-AG	100732	100733	100734	100735
TGBS 25-G1/8-AG	100736	100737	100738	100739
TGBS 25-G1/8-IG	100740	100741	100742	100743
TGBS 32-G1/4-AG	100744	100745	100746	100747
TGBS 32-G1/4-IG	100748	100749	100750	100751
TGBS 42-G1/4-AG	100752	100753	100754	100755
TGBS 42-G1/4-IG	100756	100757	100758	100759
TGBS 52-G1/4-AG	100760	100761	100762	100763
TGBS 52-G1/4-IG	100764	100765	100766	100767
TGBS 62-G1/4-AG	100768	100769	100770	100771
TGBS 62-G1/4-IG	100772	100773	100774	100775
TGBS 88-G1/4-AG	-	100776	100777	100778
TGBS 88-G1/4-IG	-	100779	100780	100781

*参见“材质性能表”以了解更多的信息

吸盘垫备件 TGB订购编号

型号	吸盘材质 * / 肖氏硬度 A			
	高温材料 HT1 60±5ShA	天然橡胶 NK 45±5ShA	丁腈橡胶 NBR 55±5ShA	硅橡胶 SI 55±5ShA
TGB 5	100782	-	100783	100784
TGB 7	100785	-	100786	100787
TGB 9	100788	100789	100790	100791
TGB 12	100792	100793	100794	100795
TGB 14	100796	100797	100798	100799
TGB 18	100800	100801	100802	100803
TGB 20	100804	100805	100806	100807
TGB 25	100808	100809	100810	100811
TGB 32	100812	100813	100814	100815
TGB 42	100816	100817	100818	100819
TGB 52	100820	100821	100822	100823
TGB 62	100824	100825	100826	100827
TGB 88	-	100828	100829	100830

*参见“材质性能表”以了解更多的信息

波纹吸盘

TGBS (2.5折)

适用于搬运易损型工件



波纹吸盘 TGBS (2.5折) 设计参数

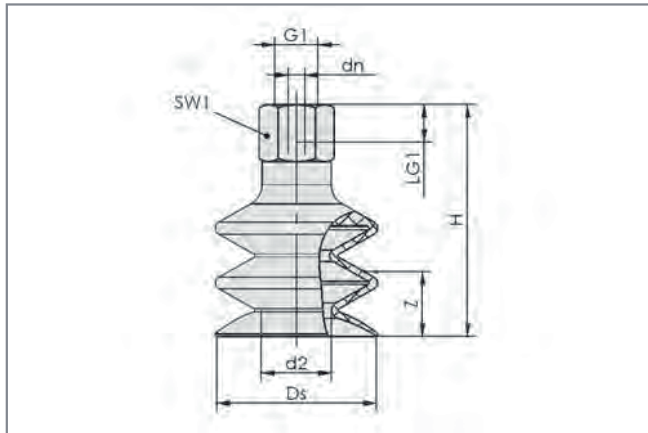

TGBS 5 至 88 IG

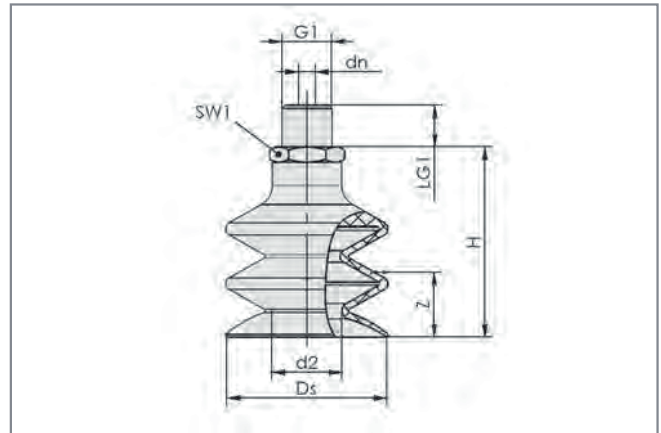

TGBS 5 至 88 AG

型号	尺寸 [mm]*							
	d2	dn	Ds	G1	H	LG1	SW1	Z (行程)
TGBS 5-M5-AG	2.6	2.0	5.0	M5-M	19.0	5.0	8	3
TGBS 5-M5-IG	2.6	2.0	5.0	M5-F	24.0	5.5	8	3
TGBS 7-G1/8-AG	1.8	3.5	5.9	G1/8"-M	20.0	7.5	14	3
TGBS 7-G1/8-IG	1.8	3.5	5.9	G1/8"-F	26.0	8.5	14	3
TGBS 7-M5-AG	1.8	2.5	5.9	M5-M	19.0	5.0	7	3
TGBS 9-G1/8-AG	4.1	3.5	9.0	G1/8"-M	21.0	7.5	14	3
TGBS 9-G1/8-IG	4.1	3.5	9.0	G1/8"-F	27.0	8.5	14	3
TGBS 9-M5-AG	4.1	2.5	9.0	M5-M	20.0	5.0	7	3
TGBS 12-G1/8-AG	5.0	3.5	12.0	G1/8"-M	27.0	7.5	14	7
TGBS 12-G1/8-IG	5.0	3.5	12.0	G1/8"-F	33.0	8.5	14	7
TGBS 12-M5-AG	5.0	2.5	12.0	M5-M	26.0	5.0	7	7
TGBS 14-G1/8-AG	5.4	3.5	14.5	G1/8"-M	28.0	7.5	14	9
TGBS 14-G1/8-IG	5.4	3.5	14.5	G1/8"-F	34.0	8.5	14	9
TGBS 14-M5-AG	5.4	2.5	14.5	M5-M	27.0	5.0	7	9
TGBS 18-G1/8-AG	8.0	3.5	17.2	G1/8"-M	28.0	7.5	14	9
TGBS 18-G1/8-IG	8.0	3.5	17.2	G1/8"-F	34.0	8.5	14	9
TGBS 18-M5-AG	8.0	2.5	17.2	M5-M	27.0	5.0	7	9
TGBS 20-G1/8-AG	10.5	3.5	20.0	G1/8"-M	28.0	7.5	14	9
TGBS 20-G1/8-IG	10.5	3.5	20.0	G1/8"-F	34.0	8.5	14	9
TGBS 20-M5-AG	10.5	2.5	20.0	M5-M	27.0	5.0	7	9
TGBS 25-G1/8-AG	10.0	3.5	23.0	G1/8"-M	40.0	7.5	14	18
TGBS 25-G1/8-IG	10.0	3.5	23.0	G1/8"-F	46.0	8.5	14	18
TGBS 32-G1/4-AG	16.0	4.4	32.0	G1/4"-M	41.5	11.0	17	15
TGBS 32-G1/4-IG	16.0	4.4	32.0	G1/4"-F	52.5	12.0	17	15
TGBS 42-G1/4-AG	17.8	4.4	42.6	G1/4"-M	50.0	11.0	17	20
TGBS 42-G1/4-IG	17.8	4.4	42.6	G1/4"-F	61.0	12.0	17	20
TGBS 52-G1/4-AG	24.6	4.4	52.5	G1/4"-M	53.0	11.0	17	25
TGBS 52-G1/4-IG	24.6	4.4	52.5	G1/4"-F	64.0	12.0	17	25
TGBS 62-G1/4-AG	29.5	4.4	62.2	G1/4"-M	59.0	11.0	17	29
TGBS 62-G1/4-IG	29.5	4.4	62.2	G1/4"-F	70.0	12.0	17	29
TGBS 88-G1/4-AG	33.0	8.0	89.0	G1/4"-M	92.0	11.0	21	34
TGBS 88-G1/4-IG	33.0	8.0	89.0	G1/4"-F	103.0	12.0	21	34

*符合 DIN ISO 3302-1 M3 橡胶件允许尺寸公差

波纹吸盘

TGBS (2.5折)

适用于搬运易损型工件



吸盘垫备件 TGB 设计参数

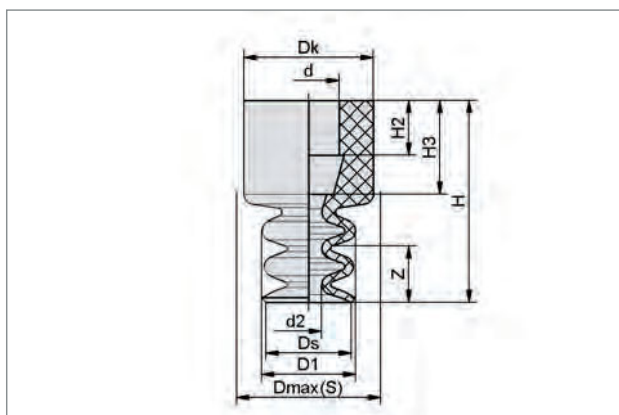

TGB-3至FG-9

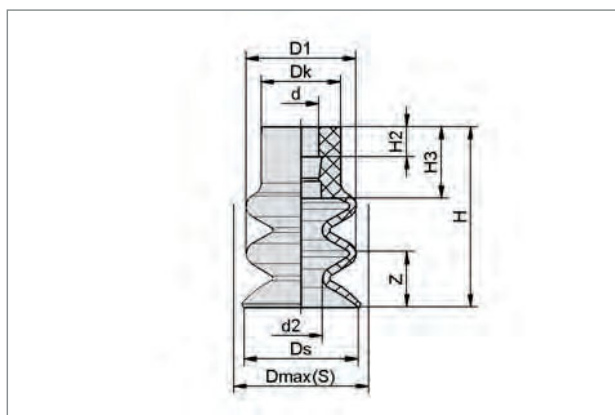

TGB-12至25

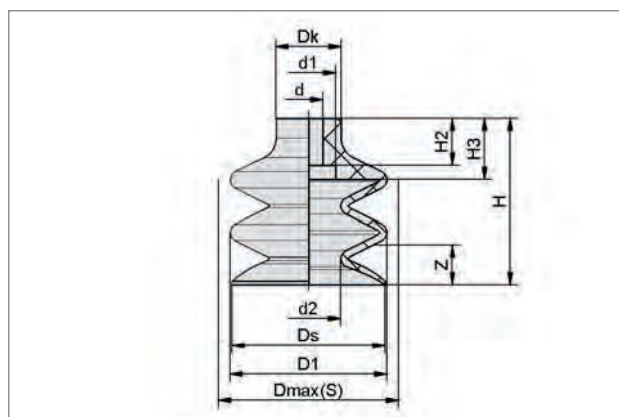

TGB-32至88

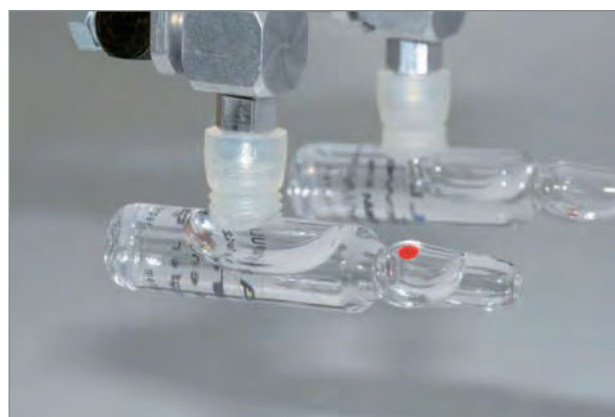

硅橡胶制成的波纹吸盘TGB应用于搬运医用安瓿

型号	尺寸 [mm]*									
	d	d1	d2	D1	Dk	Ds	H	H2	H3	Z (行程)
TGB5.0	3.5	-	2.6	6.0	7	5.0	14.0	8.0	-	2
TGB 7.0	4.5	-	1.8	6.5	9	5.9	14.0	6.5	-	3
TGB 9.0	4.5	-	4.1	8.9	9	9.0	15.0	8.2	-	3
TGB 12.0	4.5	-	5.0	12.0	10	12.0	21.0	6.9	9.0	6
TGB 14.0	4.5	-	5.4	13.9	10	14.5	22.8	6.9	9.0	9
TGB 18.0	4.5	-	8.0	17.8	10	17.2	22.6	6.9	9.0	9
TGB 20.0	4.5	-	10.5	20.0	10	20.0	22.1	6.9	9.0	9
TGB 25.0	4.5	-	10.0	25.0	10	23.0	34.0	6.9	9.0	18
TGB 32.0	8.0	15	16.0	32.6	18	32.0	37.5	13.0	17.0	15
TGB 42.0	8.0	15	17.8	43.5	18	42.6	46.0	13.0	17.0	20
TGB 52.0	8.0	-	24.6	52.0	18	52.5	48.7	13.0	-	25
TGB 62.0	8.0	-	29.5	62.0	18	62.2	54.0	13.0	-	29
TGB 88.0	11.7	25	33.0	88.2	25	89.0	86.5	19.7	26.0	34

*符合 DIN ISO 3302-1 M3 橡胶件允许尺寸公差